



# The Unimog.

The powerful implement carrier.

**Mercedes-Benz**

Trucks you can trust



# Setting standards. Redrawing boundaries. The implement carrier from Mercedes-Benz.

Progress and safety, perfection and responsibility, performance and innovation – these are just some of the values Unimog customers rightly associate with Mercedes-Benz. In the Unimog we have reinterpreted these values. The result is an implement carrier that reaches new heights where productivity, efficiency and environmental friendliness are concerned. It marries state-of-the-art commercial vehicle technology with outstanding expertise in systems and implement carriers to create a truly successful overall concept. Now more than ever: the Unimog is an investment for the future.



# Contents.

The Unimog concept	4
Advantages at a glance	6
Compact and agile	8
Ergonomic working area	10
Safety concept	14
BlueEFFICIENCY Power	16
EasyDrive traction drive	20
System and implement carrier expertise	22
Mercedes-Benz quality	28
Financial services	30
Mercedes-Benz Service	32
Technical data	34

---

Find out more at  
**[mbs.mercedes-benz.com](http://mbs.mercedes-benz.com)**

---

# Uniqueness reinterpreted: The Unimog concept.

**The Mercedes-Benz Unimog was specifically developed to work with implements. This has produced many benefits evident in practice today.**

Its operating safety and reliability, as well as outstanding system design and implement carrier know-how have made the Unimog the professional implement carrier par excellence for over 60 years now. The “Universal-Motor-Gerät” (Universal Motor Machine) – as it was originally called – is a vehicle specially designed for this purpose. Combined with the expertise of many highly-qualified implement manufacturers and bodybuilders as well as the experience and knowledge of the Unimog partners, a system has evolved with unrivalled versatility and productivity. Given its wide range of skills, its dimensions are extremely compact – and for this very reason, the implement carrier can prove its effectiveness almost anywhere.

**Superior chassis concept.**



**Superior implement-carrying concept.**



Attachment and mounting areas

**Superior chassis design: no-one gets thrown in a Unimog.**

With its sophisticated chassis design based on its sturdy ladder-type frame, it is able to master even the greatest challenges under difficult working conditions. Characteristic Unimog features are: permanent all-wheel drive, high ground clearance thanks to its portal axles, excellent ride comfort, large degree of articulation and the differential locks on both axles. The implement carrier is in its element off the beaten track, too, thanks to its single-tyre concept, Tirecontrol plus central tyre inflation system and optimal weight distribution – and will fetch speeds of up to 90 km/h (56 mph) on tarmacked roads.

**Implement-carrying expertise: the all-year-round all-rounder.**

The Unimog implement carrier has more than earned its reputation as a workhorse. It is able to provide top performance in a great variety of jobs 365 days a year. Four mounting and attachment areas make the Unimog what it is. The hydraulic, mechanical and electrical connections for the implements facilitate particularly flexible operation and provide the right drive system for each of the more than 1000 applications possible with this vehicle.



**System expertise.**

**Construction**  
 Front-mounted compressor  
 Assembly crane  
 Surface mulcher  
 Side snow cutter  
 Branch and hedge cutter  
 Trench profiler

**Boom mower**  
 Root cutter  
 Wood shredder  
 Weed brush  
 Snowblower  
 Pump water tender  
 Front-mounted sweeper

**Airport**  
 Loading crane  
 Rail gear  
 Self-rescue winch  
 Road-rail  
 Trailer towing vehicle  
 Mounted sweeping unit  
 Reflector-post washer

**Field sprayer**  
 Reflecting post washer  
 Insulated biomass tank  
 Road maintenance  
 Sower

**Fire & Rescue**  
 Rear power lift  
 Triple mower  
 Drill

**Tunnel washer**  
 Elevating work platform  
 Agricultural logistics  
 Wagon braking system  
 Oil slick remover

**Cable-laying winch**  
 Backhoe  
 Liquid salt sprayer  
 Surface-cleaning sprayer

**Power**  
 Salvaging support  
 Sewer flushing unit  
 Water tank  
 Front power lift  
 Tipper platform

**Snow cutter**  
 Snow plough  
 Irrigation boom  
 Forestry  
 Plate compactor  
 Grader  
 Tandem mower  
 Plant hole drill  
 Verge cutter  
 Snow blower-cutter

**Advanced system solutions: a vehicle with a wide variety of implements and possible applications.**

The range of tasks that the Mercedes-Benz Unimog can tackle is unprecedented. As well as all its familiar uses in very varied branches, the professional implement carrier provides a unique platform for all kinds of variations to do countless other jobs throughout the year. Mercedes-Benz has been working closely with international implement and body manufacturers for decades now, and thus combines the experience and expertise of specialists with the in-depth knowledge of competent Unimog partners. The best prerequisites are thus met for tailor-made system solutions.

# The benchmark for efficiency.

The advantages of the Unimog implement carrier at a glance.

## + Economical.

- + Use as a year-round workhorse for a wide variety of applications
- + Low consumption of fuel, AdBlue® and engine oil
- + State-of-the-art, efficient, tried-and-tested Mercedes-Benz drive technology
- + Low maintenance costs thanks to longer service intervals (1400 operating hours)
- + Easy-to-maintain cooling system
- + Powerful premium engine brake
- + Excellent protection against corrosion

## + Powerful.

- + Powerful engines with up to 220 kW (299 hp) and up to 1200 Nm of torque
- + High-performance transmission with practically-oriented graduation
- + High productivity thanks to VarioPower® power hydraulics
- + High payload and load ratings due to weight optimisation
- + Fully proportional working hydraulics for sensitive implement control
- + Driving speeds up to 90 km/h (56 mph)

## + Environmentally friendly.

- + Modern and efficient engine generation compliant with Euro VI emissions standard\*
- + Drastic reduction of emissions and particles

\*Also available for Euro V or Tier 4f.







**+ Practically-oriented.**

- + Generous panoramic cab
- + Camera monitor system with up to 3 cameras (optional) improves close-range view
- + Active and passive safety package
- + Roof-mounted windscreen wiper system

**+ User-friendly.**

- + Intuitive operating concept
- + Multifunction steering wheel
- + Modern and ergonomic interior
- + Adjustable steering column
- + High-performance heating and cooling system
- + Optional Tirecontrol plus central tyre inflation system with practical presets

**+ Innovative.**

- + EasyDrive synergetic traction drive for infinitely variable control from 0 to 50 km/h (0 to approx. 31 mph)
- + EasyDrive allows smooth switching between working and driving modes

**+ Compact and manoeuvrable.**

- + Compact dimensions for manoeuvring in confined spaces
- + Short wheelbase starting from 2800 mm
- + A small turning circle for outstanding manoeuvrability and agility
- + Rear axle auxiliary steering (optional)

# Strength that can be used almost anywhere: The compact implement carrier.

**Compactness and agility are among the central design advantages of the Unimog implement carrier.** The design engineers at Mercedes-Benz Special Trucks have once again shortened what was already an extremely compact wheelbase and given it a smaller turning circle. Also, its typically short front end dimensions, low overall height and narrow width remain features of the Unimog.

After all, the Unimog has not only been designed to use its power on roads, but also in every narrow space too. This makes the implement carrier especially productive. Because making its way through narrow streets or manoeuvring in extremely confined spaces is now even simpler – and thus also quicker. The Unimog is still one of the most compact commercial vehicles in its weight and performance class.

**And it can get even more compact: the Unimog U 216 and U 218 models.** They feature an extremely short wheelbase of 2800 mm, a turning circle of 12.6 m, compact vehicle dimensions and a gross vehicle weight of 10 t. All of which allow them to work in the most confined of spaces: when manoeuvring in old city centres or driving under low bridges or entries, for example. Due to the use of smaller wheels, their overall height is lower.

The most compact of the implement carriers: U 216/U 218



Shorter wheelbase, compact dimensions:  
the Unimog implement carrier is extremely agile.



Unimog U 216 and U 218: technology upgrade for the smallest Unimog. The great agility comes from the very short wheelbases.



The all-wheel steering increases its outstanding agility even more.

**The rear axle also steers.** The optionally-available all-wheel steering improves the typical Unimog manoeuvrability even further: it reduces the turning circle by around 20 percent and thus keeps the vehicle easy to manoeuvre in virtually every situation whilst also making it almost completely unnecessary to back up to get round tight bends. With its all-wheel steering, the Unimog can also be driven with all wheels facing in

the same direction – so-called lateral axle displacement. This mode compensates the downslope force when working on sideways inclines and also has advantages when working on snow walls. And when reversing, the all-wheel steering makes manoeuvring a lot easier as only the rear wheels are turned in the rear axle steering mode.



The all-wheel steering improves its ability to manoeuvre and has a great number of operating advantages.

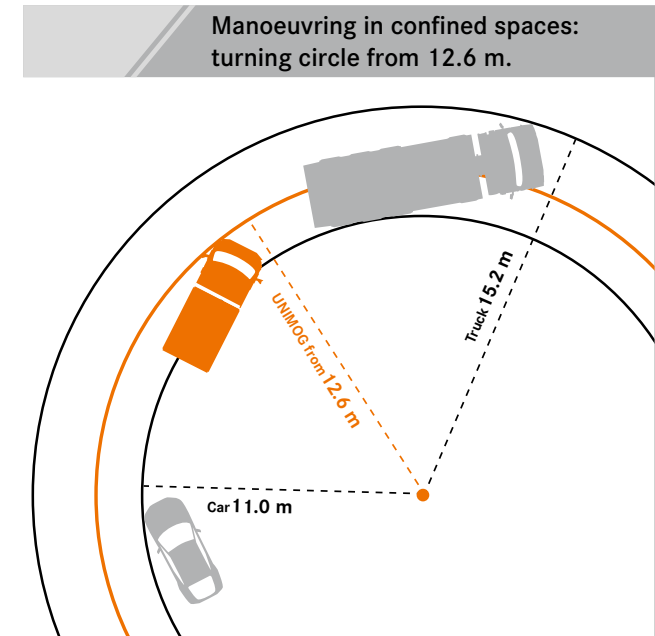

- + Short wheelbase from 2.8 m: compact dimensions and outstanding work features
- + Car-like turning circle from 12.6 m for the U 216 and U 218
- + Rear axle auxiliary steering further improves the manoeuvrability of the U 423 - U 530

# A desirable workplace.

User-friendly and ergonomic interior.

Climb in, feel good, get going: the comments and suggestions of many users contributed to the development of the cab. These include a more comfortable sitting position, improved implement operation with the multifunction joystick and a fast overview of all the vehicle displays in the instrument cluster. These improvements contribute in no small way to greater safety and ease of operation and ensure that work and comfort go hand in hand in the Unimog.





A generous atmosphere:  
The Unimog is fitted with one of  
the most modern of work places –  
and one of the most sought-after.



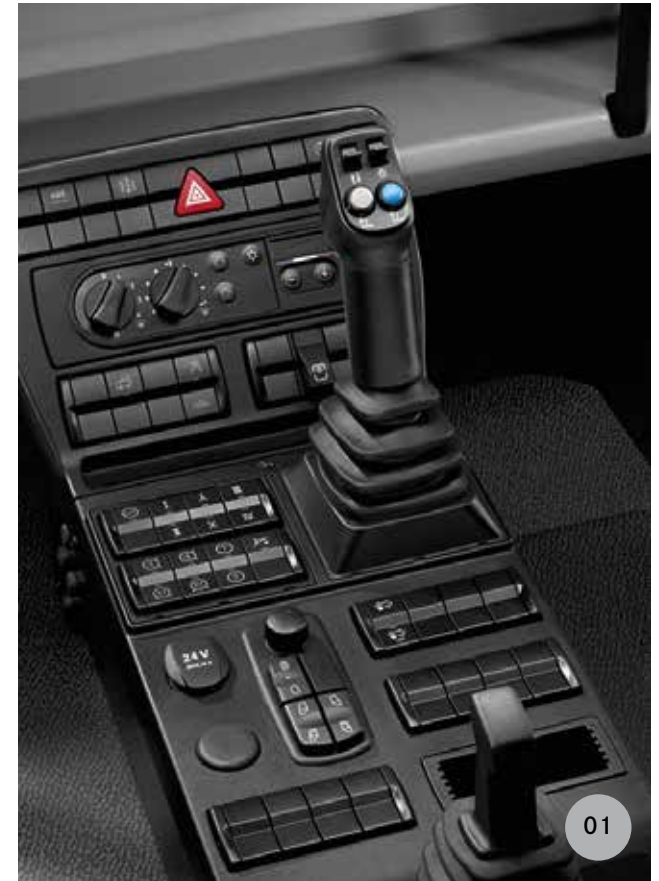
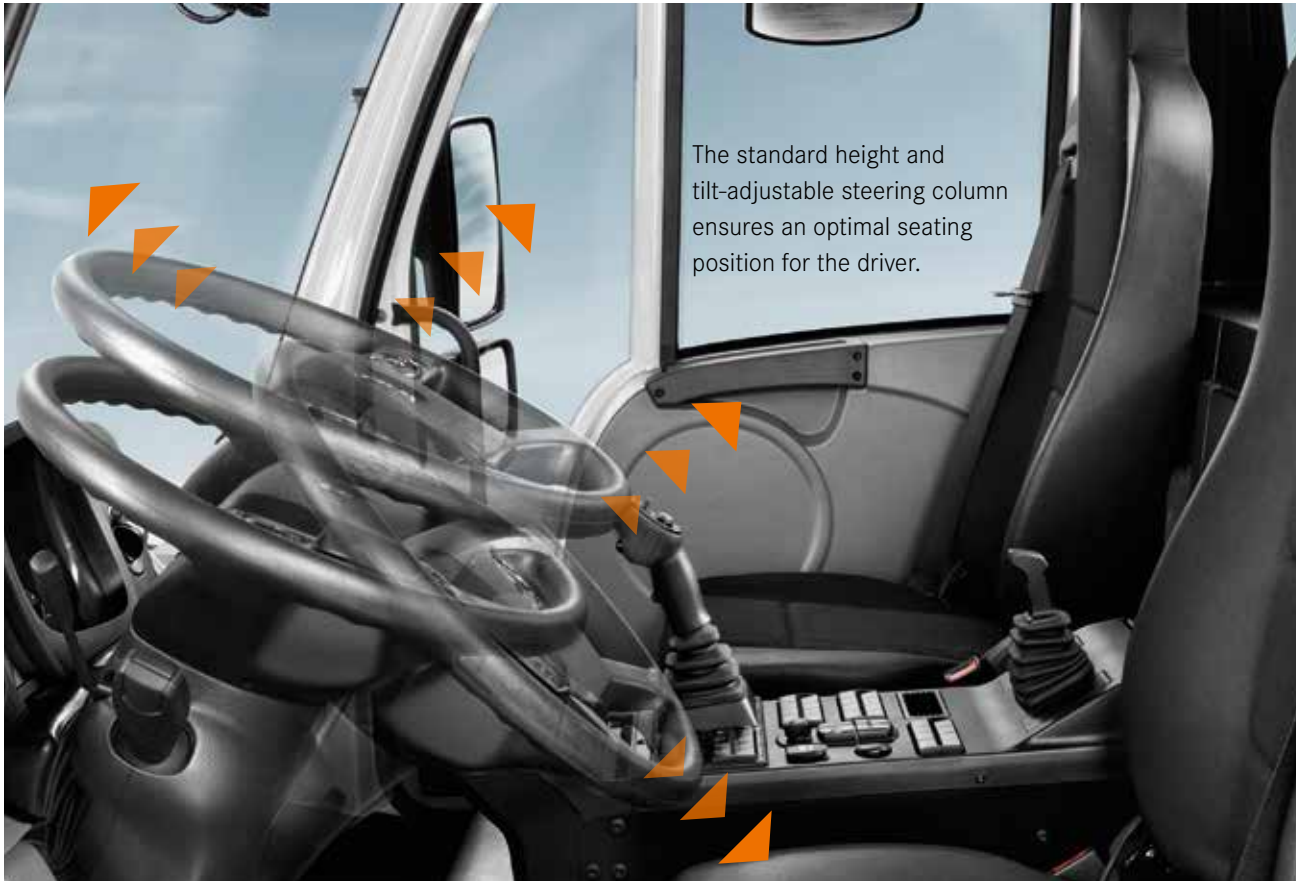

# Providing the best possible working conditions: The operating concept.

**Anyone who doesn't just drive a vehicle from A to B but works hard in it day after day will have different requirements where ease of operation and comfort are concerned.** The comfortable workplace and the cockpit, which has been optimally adapted to users' needs, together create outstanding working conditions. They help the driver to carry out the work in a concentrated yet relaxed manner. The arrangement of the controls, within optimum reach of the driver, is an example of this.

**The interior makes a very tidy impression.** In conjunction with the low-vibration cab, the optional air-sprung driver's seat reduces fatigue. Anyone spending longer periods of time in the new cab comes to appreciate the efficient air-conditioning and heating system: regardless of the weather, it ensures comfortable temperatures in the vehicle. What's more, in winter, the seat heating can be switched on. To allow work to start punctually there is a programmable auxiliary heating system. Heated windows and mirrors ensure clear vision right from the outset. And furthermore, there are a lot of practical details waiting to be discovered – such as additional stowage compartments and a CD radio with Bluetooth® hands-free system.



## Innovative details and functions of the operating concept.

- 01** In the centre console, the new removable multifunction joystick can be used to control the working functions and speed. It is also used to operate the synchronised Electronic Quick Reverse (EQR) reversing group.
- 02** The instrument cluster has a large and bright display showing all the important information, such as oil level, air pressure and the hydraulic system settings.
- 03** Driving functions such as the gear-change, engine brake (on the right) and the EasyDrive® hydrostatic drive system (on the left) are integrated in the steering column controls.
- 04** The multifunction steering wheel fits your hand perfectly and allows easy access to the display of the instrument cluster and the hands-free system.
- 05** Thanks to the optional VarioPilot® transferable steering, drivers always have the best possible seating position. A mowing door with a swivel seat is also available as an optional extra.

# The safety concept.

Great operating safety.

As a state-of-the-art commercial vehicle, the Unimog does not make any compromises when it comes to safety. With its active and passive safety systems not just users, but also other road users are very well protected. The most important features are: outstanding visibility thanks to the short front-end assembly and panoramic cab, the directional stability, ABS, precision steering, extremely good axle load distribution and the low-vibration workplace with three-point seat belt and headrest. The exterior design with a windscreen wiper system fitted to the roof improves the cleaning of the windscreen, while the headlamps with daytime driving lights improve visibility and vehicle perception. The optional front-end camera and monitoring system also improves vision in the immediate vicinity of the vehicle and makes the mounting of implements easier at the front.

---

## Safe. The Unimog.

Further information at  
[mbs.mercedes-benz.com/unimog-sicherheit](https://mbs.mercedes-benz.com/unimog-sicherheit)

---



The exterior design with its short front-end and very wide field of vision over both the driving and working areas make the Unimog a particularly safe commercial vehicle.





### The camera system with monitor.

It optimises the overall view and makes it easier to attach implements – these are the two most important advantages of the optional camera system. The system comprises a front, a rear and an additional camera which can be freely positioned for attached implements. The images can be viewed on a monitor in the interior of the cab. The driver has the area directly around the vehicle in view and, when changing implements, also has a perfect view of the front attachment plate.



### Panoramic cab.

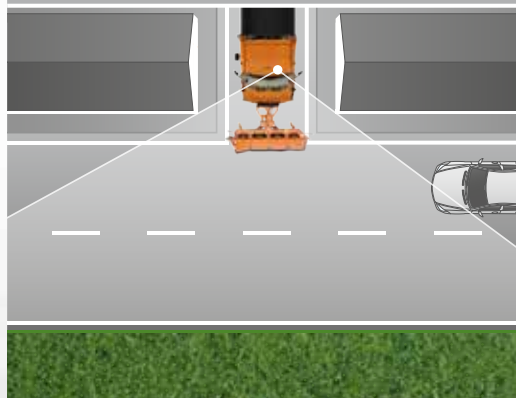

The distance between the implement and the centre of the axle and the position of the driver are especially important when working with front-mounted implements. The Unimog clearly undercuts the legal standard limit of 3.5 m even with implements attached.

### Good vehicle handling.

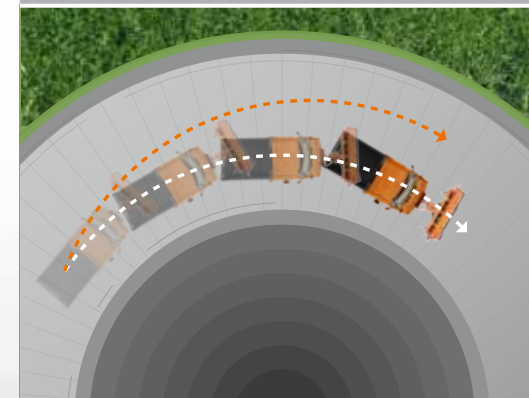

The Unimog benefits from its well-balanced axle-load distribution, especially when driving round bends on slippery roads.

# BlueEFFICIENCY Power.

Efficiently into the future.

The Unimog features many innovative transport solutions which increase efficiency and reduce emissions significantly. Courtesy of BlueEFFICIENCY Power. Under this brand name, Mercedes-Benz brings together technologies that contribute towards sustainability, environmental compatibility, CO<sub>2</sub> reduction and fuel efficiency. The basis for achieving the ambitious aims connected with BlueEFFICIENCY Power is the drivetrain with state-of-the-art diesel engines, a high-performance transmission and robust axles which make high load ratings possible on all models.

**BLUE EFFICIENCY**  
**POWER**

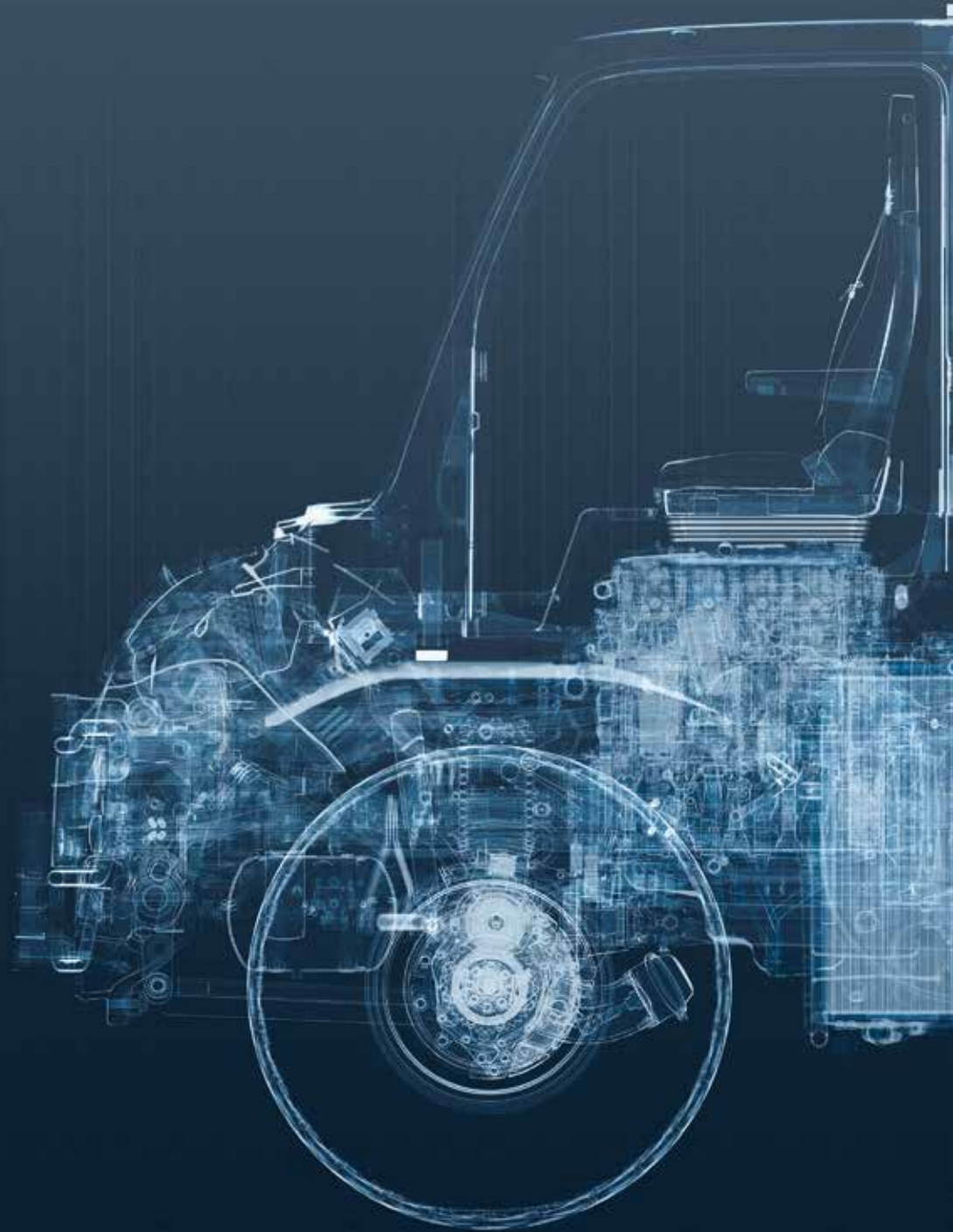

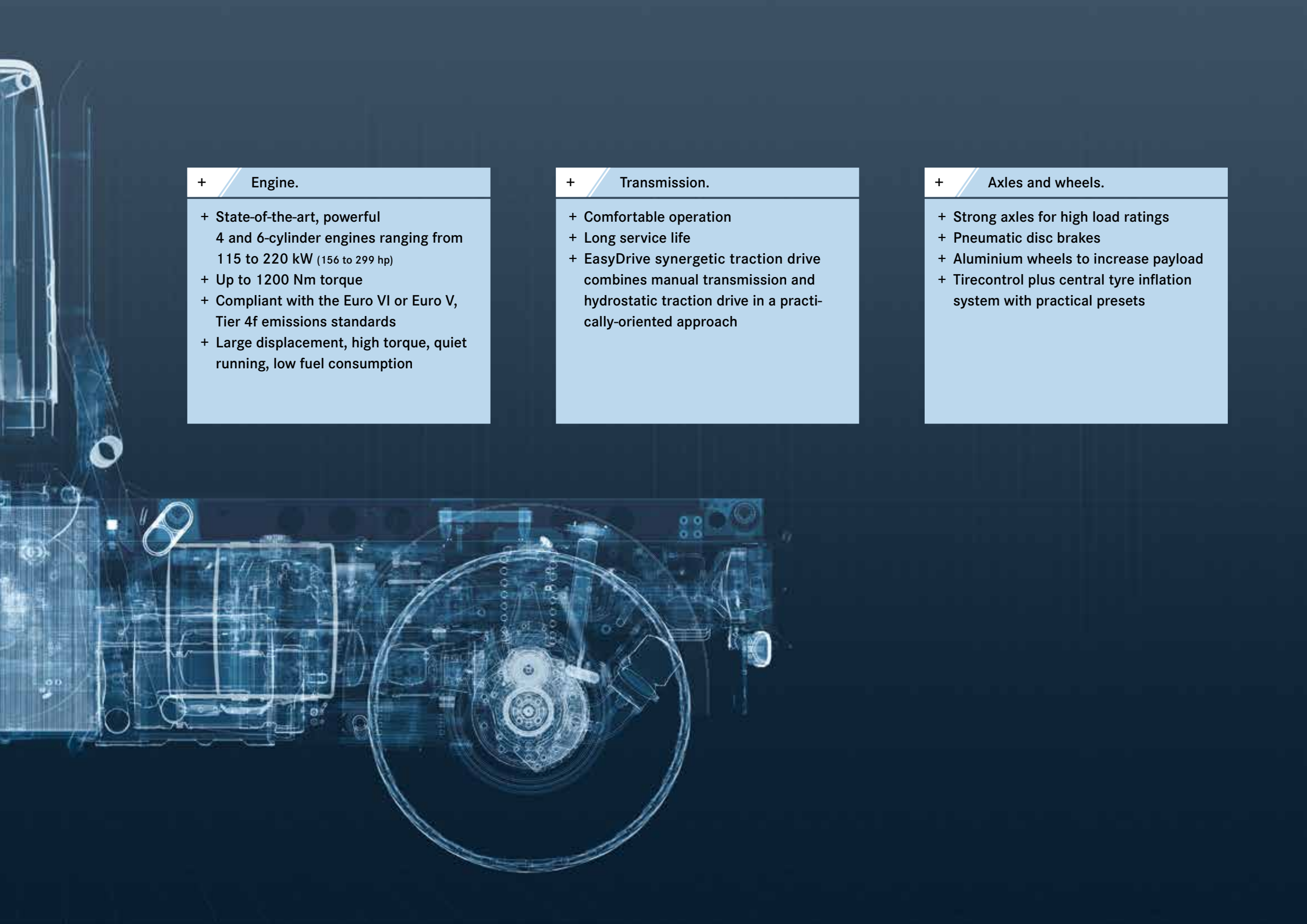

+ **Engine.**

- + State-of-the-art, powerful  
4 and 6-cylinder engines ranging from  
115 to 220 kW (156 to 299 hp)
- + Up to 1200 Nm torque
- + Compliant with the Euro VI or Euro V,  
Tier 4f emissions standards
- + Large displacement, high torque, quiet  
running, low fuel consumption

+ **Transmission.**

- + Comfortable operation
- + Long service life
- + EasyDrive synergetic traction drive  
combines manual transmission and  
hydrostatic traction drive in a practi-  
cally-oriented approach

+ **Axles and wheels.**

- + Strong axles for high load ratings
- + Pneumatic disc brakes
- + Aluminium wheels to increase payload
- + Tirecontrol plus central tyre inflation  
system with practical presets



# At the heart of economic efficiency. Perfectly coordinated drive system technology.

**The Mercedes-Benz BlueEFFICIENCY power technologies:** this generation of Mercedes-Benz engines, tested in high volume production, sets standards in its class and is designed with an uncompromising focus on environmental friendliness, economy and performance. The outstanding results are also due to the effective cooling system and the exhaust gas aftertreatment unit.

**These modern engines are particularly easy to maintain, economical, run quietly and have plenty of pulling power.** They also have high torque as well as good results for exhaust emissions, consumption and power-to-weight ratios. This means that the performance level of the strongest 4-cylinder engine corresponds to that of one of the previous 6-cylinder engines. 4-valve technology and common rail high-pressure direct injection at 2400 bar make them even more effective. The engines are also used for braking: the strong premium engine brake reduces mechanical wear and tear on the brakes and makes a great contribution to economic efficiency.

**Fewer emissions.** For the exhaust gas aftertreatment the Unimog relies on BlueTec 6 technology which has already proved its worth in daily use with heavy-duty mass-production engines. In the exhaust gas aftertreatment unit, the well-tested SCR catalytic converter reduces the nitrogen oxides to a minimum. The consumption of the AdBlue® additive required for this sinks significantly. And the diesel particulate filter prevents almost any soot particles from escaping.

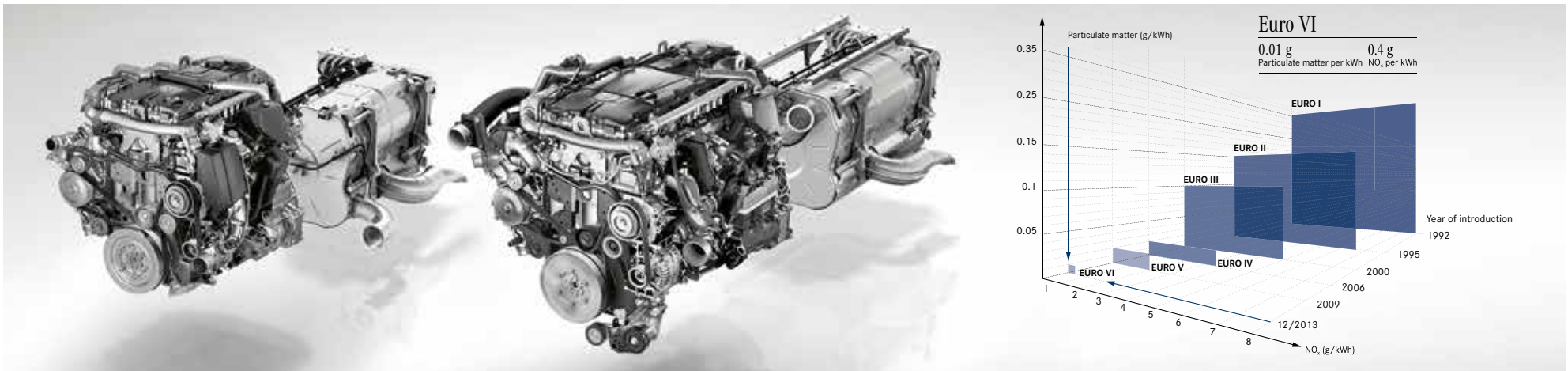

**More output, fewer emissions:** the BlueTec 6 engines are available for the Unimog as 4 and 6-cylinder units with a top performance of 220 kW. Together with the engine cooling system and the exhaust gas aftertreatment unit, these modern engines comply with the Euro VI emissions standard (selected models also comply with Euro V or Tier 4f).

**Transmission with a very effective design.** In the Unimog, the fully synchronised electro-pneumatic transmission with its eight forward and six reverse gears provides the tractive power. It is characterised by excellent smoothness of operation, a long service life and great efficiency. And the synchronised Electronic Quick Reverse feature makes it easier to change direction quickly, for instance, when clearing or manoeuvring. There is the option of a forward-reverse switch, which is integrated into the multifunction joystick.

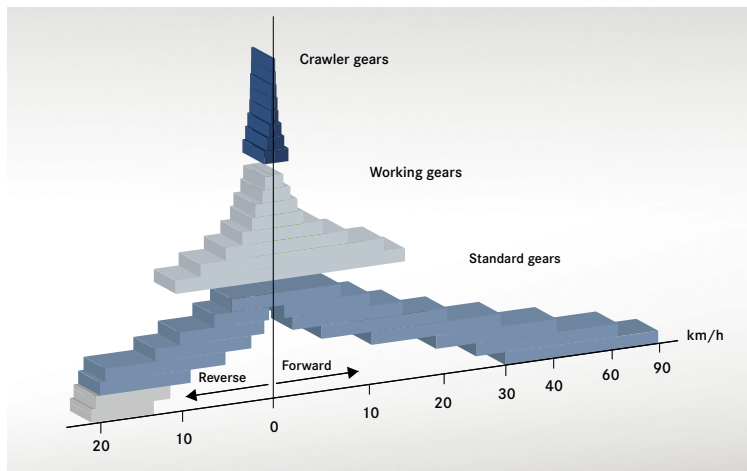

The perfect gear for every job: with a total of 24 forward and 22 or 24 reverse gears, the Unimog can offer the optimum working or road speed for the job at hand.



The steering column control on the right makes it easy to change gears. The premium engine brake is also operated from here.



# EasyDrive – the innovative traction drive system.

Adjusted precisely to the job on hand:  
The synergetic traction drive.

The EasyDrive synergetic traction drive combines the advantages of a fuel-saving manual transmission with an infinitely variable hydrostatic traction drive. The benefits become clear in practice: working speed can be set steplessly and independently of engine speed and can be maintained at that level with the speed regulator function. And if you need to move between work locations, it is simple to switch between infinitely variable and mechanical transmission modes while the vehicle is in motion. This system makes the work easier for the user and also increases productivity.

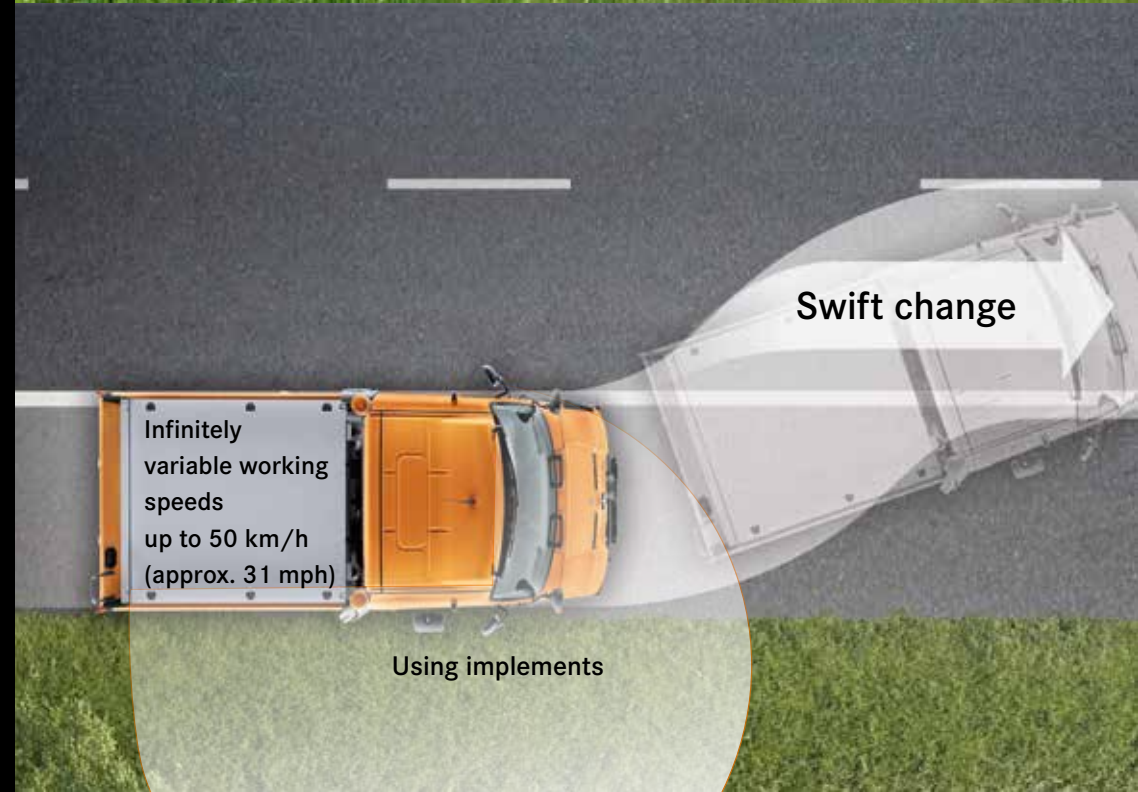





**The EasyDrive synergetic traction drive system is a leading-edge technological innovation.** This is because the traction drive is adjusted precisely to the job on hand, making it possible to use the infinitely variable speed in a much wider speed range from 0 to 50 km/h (0 to approx. 31 mph). At the same time it is extremely efficient and very easy to operate. Much higher traction is achieved with the optimised high pressure regulation and this considerably improves the performance of the Unimog implement carrier. EasyDrive allows the driver to change between mechanical and hydrostatic drive while the vehicle is in motion which makes for both efficient work with the most suitable speed and economical driving.

**No interruption when changing between working and driving modes.** The drive-work mode has proven itself to be a huge help in everyday operations: when mowing, for example, if a section has been completed, the manual transmission can be actuated easily and speedily. This is how it's done: when the maximum speed of 50 km/h (approx. 31 mph) is reached for the hydrostatic drive, the switch is made to manual transmission by actuating the clutch or, optionally, by switching automatically. This makes it faster and safer to merge into lanes of moving traffic. And with EasyDrive, the decision as to which drive mode is the most suitable is taken spontaneously without the need to brake.

#### EasyDrive.

**The synergetic traction drive can be varied simply in four different ways:**

- + With the accelerator pedal and brake
- + Using the work cruise control
- + With the left-hand steering column control
- + With the multifunction joystick

**Other advantages:**

- + Gear selection is possible while driving
- + Smooth changeover between manual transmission and hydrostatic traction drive
- + Simple to operate and activate
- + Work mode for operating with constant engine speeds
- + Drive mode for infinitely variable speeds from 0 to 50 km/h (0 to approx. 31 mph)
- + Choice of operations-related driving modes: "efficient", "comfortable" and "powerful"



**EasyDrive steering column control:** operators can change both the driving direction and gear as well as set the cruise control with their left hand, whilst at the same time have the right hand free to use the multifunction joystick for positioning implements, for example.

# System and implement carrier expertise.

A convincing all-rounder: the Unimog implement carrier is characterised by its versatile operation.

The Unimog has been without equal for generations now where versatility in all-year-around utilisation is concerned. The reason for this: the implement carrier is a unique vehicle concept which has been specially designed for use with implements. Together with our many qualified implement partners, we draw up individual system solutions to increase productivity and use the vehicle fleet to the full. The implement carrier is also the top performer when it comes to driving and controlling implements. And the removable multifunction joystick makes operations much simpler and thus safer.

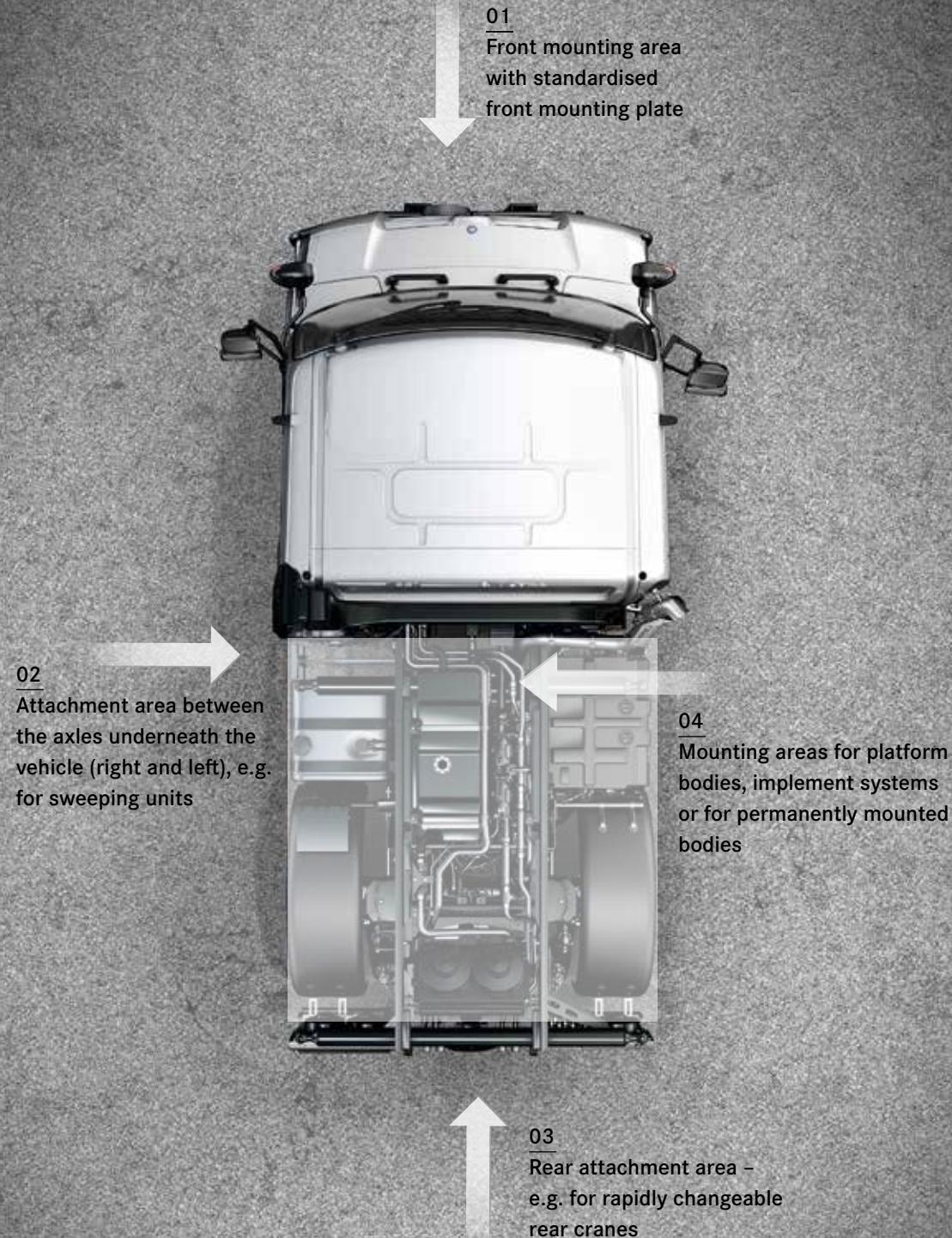





Intuitive implement control with the removable multifunction joystick.



Four attachment and mounting areas: the Unimog implement carrier is one of the most productive work vehicles there is. Many different implements can be combined thanks to the standardised interfaces. These include the front mounting plate, attachment points on the frame, mounting brackets on the sides and at the rear as well as ball-point positions on the platform sub-frame.

### Powerful and versatile operation.

- + A great variety of uses are possible with the Unimog in combination with various implements
- + Most existing implements are compatible
- + Four attachment and mounting areas and standardised interfaces
- + The mounting brackets at the rear can bear loads of up to 2.5 t

**The combination of attachment and mounting areas as well as hydraulic and mechanical implement drives and controls turns the vehicle into a genuine workhorse.** The sturdy ladder-type frame with integrated mounting positions provides the basis for the wide range of work the Unimog can do.

**Working together to provide top quality:** highly specialised implement manufacturers and bodybuilders have created solutions which make it possible for customers to use the vehicle to the full for a wide variety of applications. This means that we and our partners can ensure lasting high quality for the entire vehicle.

**Altogether the Unimog provides one mounting area and three attachment areas:**

- + Attachment areas are to be found at the front, between the axles and at the rear. They can be used at the same time which makes operations very efficient. The standardised front attachment plate makes changing implements especially easy.
- + The mounting area is on the platform. Mounted bodies can be fastened directly onto the ladder-type frame or onto ball point positions on the platform sub-frame. If the platform is removed, the payload can be increased considerably.





The Unimog is even capable of performing very complex movements fast and sensitively. Snow plough relief improves traction and reduces wear.

# The fully proportional working hydraulics.

**The working hydraulics control implements precisely and comfortably.** Two positioning movements can be done at the same time – simply by using the multifunction joystick. Further functions can be set via the steering wheel buttons. Larger trailer tipping cylinders can also be filled with up to 30 litres of hydraulic oil to draw on as required. Circuit I controls up to eight implement adjustments with a system pressure of 210 bar (32 l/min) over four dual-operation valves; alternatively it drives hydraulic motors at the lower output range.

**The four-cell working hydraulics of the implement carrier consist of two circuits.** When combined, circuits I and II (32 plus 55 l/min) can now mobilise 35 kW at up to 240 bar.

**Another highlight is the load sensing hydraulic system.** With a hydraulic oil flow rate of up to 110 l/min and 240 bar pressure which adapts the pump pressure or the volume flow constantly to suit requirements, making it both particularly efficient and at the same time very economical.



The separate tipping hydraulics allow tipper bodies or trailers to be tipped independently of the working hydraulics.

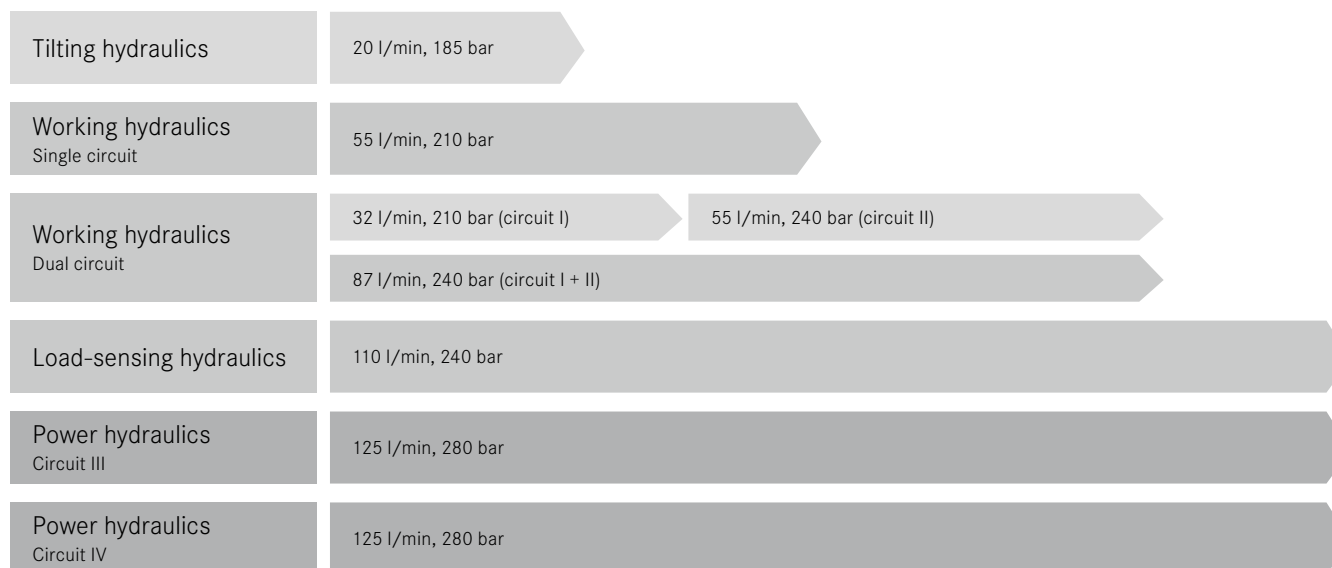

# Powerful and efficient: The VarioPower<sup>®</sup> power hydraulics.

**Two circuits, both with 125 l of hydraulic oil flow per minute and 280 bar pressure: it doesn't matter how hard the work is, with its power hydraulics the Unimog is able to cope.** Regardless of whether several work operations have to be done at the same time or if a job needs more power – VarioPower<sup>®</sup> is capable of even more. The two open circuits III and IV have the same high through-flow of 125 l, system pressure of 280 bar and a maximum output of 58 kW. The power hydraulics can therefore take the place of plug-in pumps

on the PTO shaft or diesel special purpose body engines. VarioPower<sup>®</sup> controls are simple to operate using the steering wheel buttons on the multifunction steering wheel. The settings are shown in the instrument cluster. The power hydraulics are installed on the platform sub-frame and can also be removed if necessary – for instance to increase the payload for winter services.



With its hydraulic systems, the Unimog is able to do up to three jobs at the same time with its triple mowing combination.

## Fast and easy cleaning of the cooling system.

The new cooling system and component arrangement ensures the cooling of all of the units even when ambient temperatures are high, driving speeds low and jobs exceedingly dirty. Cleaning of the cooler is also very easy: open the grid and blow the filter clean with the compressed air pistol. The cooler can also be cleaned automatically – with the optional reversing fan (reversing the airflow) which features multi-timer interval control.



Hydraulic connections for up to four circuits are safely installed at the front and rear of the vehicle.

# Mechanical implement drive system: proven power.

**Full steam ahead: for many jobs, the mechanical implement drives have just the right output.** The Unimog has a whole range of them at the ready as optional extras: a front PTO with a continuous output of 160 kW. On-board engine and transmission power take-off are also available as an option. The mechanical drive systems are good for jobs requiring a high output.

**Powerful front PTO with up to 160 kW: the direct source of power.** Front-attached implements requiring a great deal of power are run off the front PTO which takes its power directly from the drivetrain of the engine. It is oil-cooled as a standard feature and has a high torque transfer and a very high degree of efficiency with a 1¾" splined shaft – especially in continuous operation. With the engine speed indicator in the instrument cluster and setting between 420 and 1000 rpm, the PTO can be used to drive implements at 540 rpm or 1000 rpm standard engine speed.

**PTOs from engine and transmission: two further performance options.** The engine-run PTO of the Unimog implement carrier drives the power hydraulics, but it can also be used to run powerful implements in combination with a hydrostatic drive. The transmission-run PTO with its standardised flange on the manual transmission also allows commercially available hydraulic pumps to operate cranes and elevating work platforms. Output speed and rotational direction are identical to engine speed and rotational direction.



Working with the front PTO: high power reserves even when using very output-intensive implements such as a snow cutter.

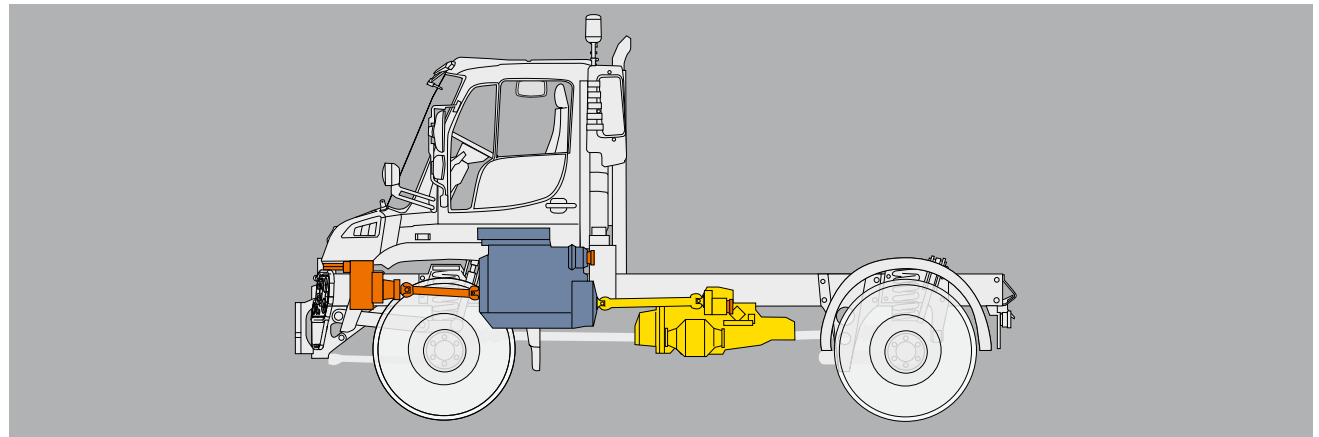

The positions for the front PTO (orange), the engine-run PTO (blue) and the transmission-run PTO (yellow).





# Electrical interfaces: plug in and work.

Four standardised sockets in the cab and on the outside allow electrical consumers to be connected or implements to be operated – without any need for lengthy cabling. The on-board electrical system is fed by a 24-volt/ 150 Amp generator. The parameterisable on-board electronics make it easier to control settings such as the engine speed limiter to protect mechanically-driven implements, the drive-off lock for extended supports or the speed limiter.



# Mercedes-Benz quality.

The Unimog integrates leading commercial vehicle technology that is already proven in large-scale production.

**Built in Wörth, at the largest truck assembly plant in the world: the Unimog meets the high quality standards of the commercial vehicle branch.** As a global leader of medium-heavy and heavy trucks, Mercedes-Benz sets itself ambitious targets: standards are what define quality and reliability. And the workforce of over 11,000 located at the modern and environmentally-friendly Wörth plant also meet these expectations. Since 1963, over three million commercial vehicles have been manufactured here. Alongside the so-called A-series (Actros, Arocs, Antos and Atego), Mercedes-Benz

Special Trucks also designs and manufactures all its vehicles at the plant, using a good number of identical components. The fleet comprises the Unimog implement carrier, the outstandingly agile off-road Unimog, the Econic and the Zetros. The model series are all subject to the same extremely strict testing and trial cycles as the large-scale production series. The passion for commercial vehicles is best expressed by the motto of the workforce at the Wörth plant: “We aspire to get a little better each day to fulfil our brand pledge to our customers: Trucks you can trust.”



**Mercedes-Benz Wörth plant:** the Mercedes-Benz Unimog is designed and manufactured at the world's largest truck production plant. The engines come from the Mercedes-Benz engine plant in Mannheim.



**High quality standards:** Mercedes-Benz sets itself very high quality standards for every Unimog produced – from its development, during its testing and in its production.









# Financial services.

Flexibility that gives plenty of elbow room.

**Our customised financial services make your accounting more flexible.** Jointly with the Mercedes-Benz Bank and our Unimog partners, we can provide customised service offers such as leasing, financing, prolonged guarantees, mobility concepts and rental vehicles. Contact your authorised Unimog partner for more information.

## Creating added value. Daimler Financial Services.

- + Daimler Financial Services finances and leases about 40% of all vehicles produced by Daimler worldwide Production
- + The company with its headquarters in Stuttgart is active in almost 40 countries and of all the automotive financial service providers it offers the most international experience
- + Daimler Financial Services employ around 7000 staff worldwide

**Financing.** Flexible offers to widen your financial scope. For instance, seasonal payment financing, which means that you pay more in busy months and less in quiet months, or final payment financing which has a higher final payment so that the monthly rates are lower, or Plus3 financing. At the end of the contractual period, you can then decide whether to sell your Unimog and make the final payment or whether to return the vehicle to your Dealer at the price guaranteed in your contract<sup>1</sup>. You can also keep your Unimog when you make the final payment. Make the most of taking a follow-up financing and repay the final payment in reasonable monthly payments. Even when you take the standard financing, you are guaranteed to get attractive and flexible terms. When you have decided which new vehicle you would like, talk to your sales representative to settle the terms for its financing.

**Terminable lease contract.** The greatest flexibility with lower payments: after a minimum rental period of 24 months, you can terminate the contract by giving a month's notice – and then have a choice of follow-up options: you can return your Unimog and take a different model as required or buy the vehicle from your Mercedes-Benz partner.

**Leasing.** Instead of paying the entire purchase price, you can also pay for the use of the vehicle with a leasing contract from the Mercedes-Benz Bank. You then agree on convenient monthly payments over a period of time arranged with your Mercedes-Benz partner to suit your requirements. Be kind to your budget and make the most of easy-to-calculate and transparent costs.

<sup>1</sup> This option is based on an additional agreement between you and your dealer.

**Mercedes-Benz Bank Service Leasing.** One contract, many advantages. With this attractive package you can regulate the greater part of your fleet costs: acquisition and service. This gives you the greatest planning security.

**Local Authority Leasing.** With our Local Authority Leasing we can provide every public budget with a suitable solution. You can change to new vehicles at regular intervals which means you get a modern and economical fleet at the same time. It doesn't matter whether it is for ambulances, fire tenders or road maintenance – with Local Authority Leasing, you're making the right decision.

**Your Unimog partner will be pleased to give you a customised offer. Why not contact them now?**



# Mercedes-Benz Service.

We're committed to your mobility.

**Wherever you put your Unimog to work, Mercedes-Benz is close at hand.** At over 650 Unimog Service Support Points in more than 130 countries around the world, we will take care of your Unimog straight away if you need us to. With the same care and attention to detail, the same expertise and the same technical resources that we put into its original assembly. This comes courtesy of our countrywide service network manned by knowledgeable Unimog partners.

**We respect experience.** Including that of others. For our services, it is the active care that is important. The open exchange of experience is part of this. And not just with our customers, but also with our colleagues. In this way, efficient and economic solutions can be found. This enables our service partners to meet our very high standards every day as far as quality, costs and environmental awareness are concerned. By making clear statements, providing clear fault analysis and cost-oriented solutions. And if parts have to be changed, then of course only Mercedes-Benz Genuine Parts which have met our stringent quality and availability standards are ever used.



## What you can expect from Mercedes-Benz:

- + First-class service quality at over 650 locations in more than 130 countries worldwide
- + Maintenance, diagnosis and repairs
- + Technical support and personal attention
- + Advice and training to suit requirements
- + Driver, safety and technical training
- + Partnership and fairness

## Top service offers from Mercedes-Benz Special Trucks.

- + **Service Extend:** drivetrain guarantee concerning the engine, transmission and much more
- + **Service Extend Plus:** follow-up guarantee for the whole vehicle concerning the engine, transmission and much more
- + **Service Mobility:** local service, fetch and return service, rental vehicle for the driver (only valid for a maximum of two years and only in conjunction with Service Extend Plus)
- + **Service Complete:** full-service package for maintenance work and normal wear and tear as well as repairs (except those concerning attachments and bodies)
- + Mobility for local authorities by providing fully equipped vehicles (subject to availability, only valid for a maximum of two years)





## Overview of models for Euro VI\*

MODEL	MODEL VARIANT	WHEELBASE (mm)	ENGINE	OUTPUT (kW/hp)	NO. OF CYLINDERS/ ARRANGEMENT	PERMISSIBLE GROSS VEHICLE WEIGHT FROM-TO (t)
U 216	405.090	2800	OM 934 LA	115/156	4	7.49-10.0
U 218	405.090	2800	OM 934 LA	130/177	4	7.49-10.0
U 318	405.104	3000	OM 934 LA	130/177	4	7.49-11.0
U 323	405.105	3000	OM 934 LA	170/231	4	12.1-13.8
U 423	405.105	3000	OM 934 LA	170/231	4	12.1-13.8
U 427	405.110	3150	OM 936 LA	200/272	6	12.1-14.0
U 430	405.110	3150	OM 936 LA	220/299	6	12.1-14.0
U 323	405.125	3600	OM 934 LA	170/231	4	12.1-14.0
U 423	405.125	3600	OM 934 LA	170/231	4	12.1-14.0
U 427	405.125	3600	OM 936 LA	200/272	6	12.1-14.0
U 430	405.125	3600	OM 936 LA	220/299	6	12.1-14.0
U 527	405.202	3350	OM 936 LA	200/272	6	12.1-16.5
U 530	405.202	3350	OM 936 LA	220/299	6	12.1-16.5
U 527	405.222	3900	OM 936 LA	200/272	6	12.1-16.5
U 530	405.222	3900	OM 936 LA	220/299	6	12.1-16.5

Note: U 323 can, at present, only be ordered for the countries D/CH/A.

## Overview of models for Euromot IV/Tier4f\*

MODEL	MODEL VARIANT	WHEELBASE (mm)	ENGINE	OUTPUT (kW/hp)	NO. OF CYLINDERS/ ARRANGEMENT	PERMISSIBLE GROSS VEHICLE WEIGHT FROM-TO (t)
U 423	405.105	3000	OM 934 LA	170/231	4	12.1-13.8
U 429	405.110	3150	OM 936 LA	210/286	6	12.1-14.0
U 529	405.202	3350	OM 936 LA	210/286	6	12.1-16.5

## Overview of models for Euro V\*

MODEL	MODEL VARIANT	WHEELBASE (mm)	ENGINE	OUTPUT (kW/hp)	NO. OF CYLINDERS/ ARRANGEMENT	PERMISSIBLE GROSS VEHICLE WEIGHT FROM-TO (t)
U 423	405.105	3000	OM 934 LA	170/231	4	12.1-13.8
U 429	405.110	3150	OM 936 LA	210/286	6	12.1-14.0
U 423	405.125	3600	OM 936 LA	170/231	4	12.1-14.0
U 429	405.125	3600	OM 936 LA	210/286	6	12.1-14.0
U 529	405.202	3350	OM 936 LA	210/286	6	12.1-16.5
U 529	405.222	3900	OM 936 LA	210/286	6	12.1-16.5

\* Country-specific registration regulations must be observed

# The whole world of the Unimog.

Services to keep you mobile and flexible.

Find out more about additional ways of using the Unimog.

The Mercedes-Benz Unimog performs at the highest levels in other industries and segments too, with its unique versatility ensuring it can always be used to full capacity.

## +++ Mercedes-Benz replacement parts.

**Original parts for perfect interaction and maximum functionality:** your Unimog Service Partner supplies Mercedes-Benz Genuine Parts – either as new or as reconditioned parts. You get the benefit of first-class Mercedes-Benz quality, excellent value for money and a long service life. You can also obtain exclusive Mercedes-Benz genuine retrofit accessories from your Unimog Service Partner.

- + Mercedes-Benz Genuine Parts
- + Mercedes-Benz Genuine Remanufactured Parts
- + Optimum availability
- + Outstanding value for money
- + Warranty and follow-on warranty for parts and assemblies

## +++ Contact and more.

**Want to know more?** Competent, individual advice. As your one-stop supplier, your Unimog dealer will provide you with the customised solution you require – and you can rest assured that your overall system comprising vehicle and attachments is perfectly matched and has been tested according to the strictest criteria. We will happily put you in contact with one of our specialist Unimog dealers.

**Unimog E-News.** Stay up to date - one-off registration: Unimog E-News provides you with valuable background information, testimonials and news about the Unimog.

**Mercedes Benz Special Trucks World.** Everything is online there – exciting reports on practical operations, interviews, pictures and many videos on the Unimog, Econic and Zetros.

**Discover it now:** [mbs.mercedes-benz.com](http://mbs.mercedes-benz.com)



MUNICIPAL



FIRE & RESCUE



ROAD-RAIL



ENERGY



CONSTRUCTION



... AND MUCH MORE



**Please note:** Changes may have been made to the product since this publication went to press (01.01.2017). The manufacturer reserves the right to make changes to the design, form, colour and scope of delivery during the delivery period, provided that these changes, whilst taking into account the interests of the vendor, can be deemed reasonable with respect to the purchaser. Where the seller or the manufacturer uses symbols or numbers to describe an order or the subject of an order, no rights may be derived solely from these. The illustrations may show accessories and items of special equipment which are not part of standard specification. Colours may differ slightly from those shown in this publication, owing to the limitations of the printing process. This publication may contain models and services which are not available in certain countries. Information given regarding statutory regulations, legal requirements and taxation and the consequences thereof applies to the Federal Republic of Germany only and is correct at the time of going to press. To find out about the current status of these regulations and their implications, please ask your Unimog partner. [www.mercedes-benz.com](http://www.mercedes-benz.com)